

Easier, Safer Rack Maintenance: No More Strain, No More Hassle.



Jamesway 3 column rack being tilted



Tilted rack with egg flats

BENEFITS

- One person operation
- Light weight, easy to move
- Easy to store
- Allows for the casters to be changed, greased and cleaned at a comfortable level
- No more heaving lifting for laying down or raising the racks, protects workers back and fingers
- Can be used with all brands of farm and incubator racks- Jamesway, Chick Master, Pas Reform, Emtech, Emka, Hatchtech

SAFETY FEATURES

- 12-volt operation with a power converter to 110 V
No chance of shock
- Hydraulic power pack needs 2,500 PSI, all hose are 4,800 PSI
- The unit will not operate unless the up or down button is continuously pressed - no need for ESTOP
- Hydraulic fluid is food grade
- 8" Swivel casters lock in position so that the unit will not move when in use
- Visual alarm by way of yellow flashing light
- Audio alarm with 93 DB sound level

WARRANTY

- 9 months on Hydraulic power pack
- 9 months on Power Converter
- 9 Months on cylinder
- Material only warranty based on manufacturing defects

WARNINGS

- Lifting capacity of 750 LBS
- Do not spray with water, clean with damp cloth only

FRONT VIEWS (Handle in Upright & Down Positions)

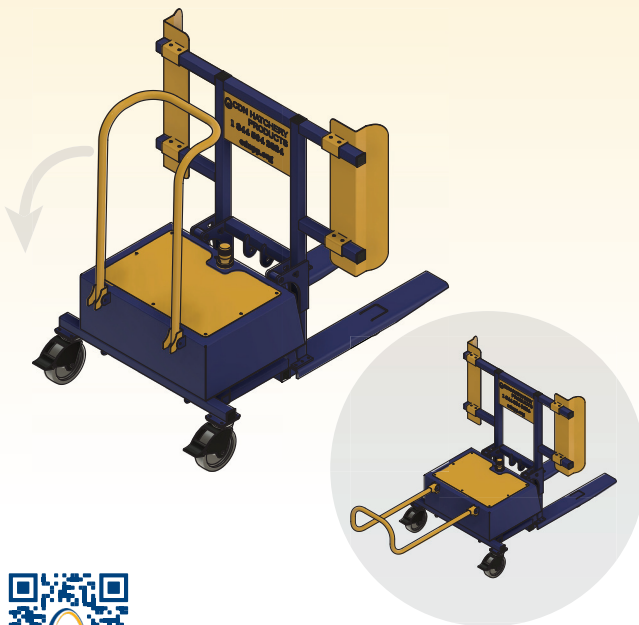

REAR VIEW

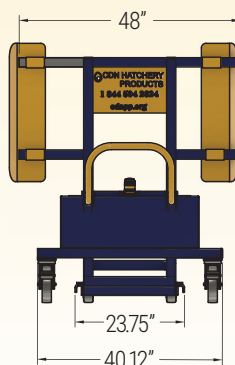

SIDE VIEWS (Handle in Upright & Down Positions)

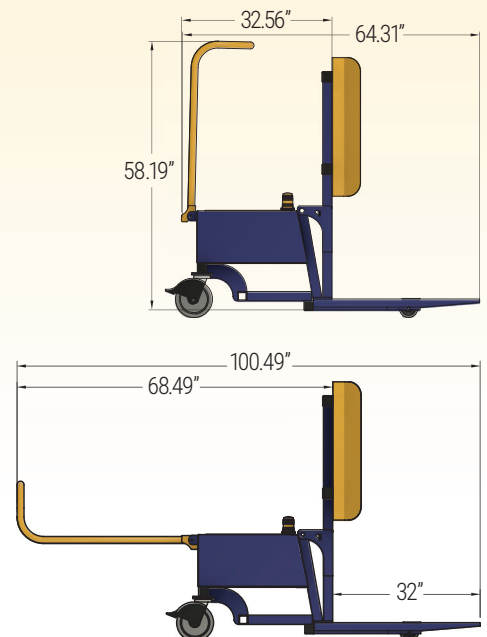

SCAN for video demos